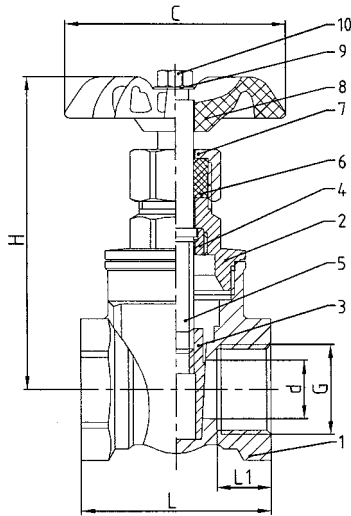

## ARITA BRASS GATE VALVE

**CLASS 125 GATE VALVE (BSPT)**

ARV-1001SE

**STANDARD COMPONENT MATERIAL**

NO	DESCRIPTION	QTY.	MATERIAL
1	Body	1	Brass
2	Bonnet	1	Brass
3	Disc	1	Brass
4	Lock Nut	1	Brass
5	Stem	1	Brass
6	Stem Packing	1	PTFE
7	Packing Nut	1	Brass
8	Handwheel	1	Aluminium
9	Name Plate	1	Aluminium
10	Wheel Nut	1	Steel

**SPECIFICATIONS**

- Brass body and bonnet
- Screwed end (BSPT)
- Applicable temperature : -20 ~ 120 ° C
- Applicable media : W.O.G. and steam

**TEST PRESSURE**

Nominal Pressure	:	1.6 MPa
Shell Test Pressure	:	2.4 MPa
Seat Test Pressure	:	1.8 MPa

**DIMENSION TABLE (MM)**

DN	L	L1	d	H	C	G	Weight (Kg)
15	42	12	13	71	50	1/2	0.24
20	46.5	13.5	19.5	71	55	3/4	0.34
25	50	13.5	25	93	60	1	0.45
32	59.5	15.5	31.5	111	70	1-1/4	0.68
40	63	16	37	121	80	1-1/2	0.90
50	71	19	49	153	90	2	1.50
65	81.5	22	55	186	100	2-1/2	2.71
80	92	24	66	200	115	3	3.56
100	114	29	84	236	115	4	6.50